

MULTIPLE CHOICE. Choose the one alternative that best completes the statement or answers the question.

Select from the list of numbers all that belong to the specified set.

- 1) Natural numbers 1) _____
 $9, \sqrt{6}, -10, 0, \frac{0}{9}, \sqrt{9}$
 A) 9, 0 B) $9, 0, \frac{0}{9}$ C) $9, \sqrt{9}$ D) $9, 0, \sqrt{9}$

- 2) Rational numbers 2) _____
 $9, \sqrt{6}, -20, 0, \frac{0}{2}, \sqrt{16}, \frac{-4}{0}, 0.09$
 A) $\sqrt{6}, \sqrt{16}$ B) $9, -20, 0, \frac{0}{2}, \sqrt{16}, 0.09$
 C) $9, 0, \sqrt{16}$ D) $\sqrt{6}, \frac{0}{2}, 0.09$

Write the number in scientific notation.

- 3) 0.000462 3) _____
 A) 4.62×10^4 B) 4.62×10^{-5} C) 4.62×10^{-3} D) 4.62×10^{-4}

Write the number in standard form.

- 4) 2.0620×10^6 4) _____
 A) 123.72 B) 206,200 C) 2,062,000 D) 20,620,000

Find the percent change if a quantity changes from P_1 to P_2 . Round your answer to the nearest tenth if appropriate.

- 5) $P_1 = \$13, P_2 = \51 5) _____
 A) -74.5 B) 292.3 C) -292.3 D) 74.5

Use the information given in the table to solve the problem.

- 6) The table gives the Consumer Price Index for selected years. 6) _____
- | | | | | | |
|------|------|------|------|------|------|
| Year | 1960 | 1965 | 1970 | 1975 | 1980 |
| CPI | 29.1 | 36.8 | 47.7 | 64.2 | 84.2 |
- What is the percent change (to the nearest tenth of a percent) in prices from 1965 to 1980?
 A) 127.6 % B) 128.8 % C) 229.2 % D) 131.1 %

Solve the problem.

- 7) An oil spill of 4186 cubic centimeters is spilled onto a pond and spreads out in a circular shape 7) _____
 having a diameter of 298 centimeters. Approximate the thickness of the oil film to four decimal places, using volume = area x thickness(height).
 A) 8.9426 cm B) 0.06 cm C) 16.6618 cm D) 4.4713 cm

Use the information given in the table to solve the problem.

8) The table gives the value of a 1957 Chevy BelAire in #2 condition for selected years.

8) _____

Year	1980	1982	1984	1986	1988
Value in dollars	8140	8455	9927	10,592	12,719

Use the concept of an average or mean to estimate the value of a 1957 Chevy BelAire in #2 condition in 1983.

- A) \$ 9161.87 B) \$ 9181.00 C) \$ 9220.13 D) \$ 9191.00

Find the mean of the set of data. Round to the nearest tenth.

9) 120, 47, 2, 32, 81, 26, 55, 95, 14

9) _____

- A) 43.4 B) 52.4 C) 59.0 D) 50.9

Find the median of the set of data.

10) 44, 139, 228, 231, 387, 422

10) _____

- A) 229.5 B) 207.5 C) 231 D) 228

Find the distance in the xy-plane between the two points. Round an approximate result to the nearest hundredth.

11) (-5, -1) and (-13, -7)

11) _____

- A) 10 B) -10 C) 3.16 D) 24

Find the midpoint of the line segment joining the two points.

12) (-4, -9) and (3, -7)

12) _____

- A) (-1, -16) B) $\left(-\frac{7}{2}, -1\right)$ C) $\left(-\frac{1}{2}, -8\right)$ D) (-7, -2)

Make a scatterplot of the relation.

13) $\{(5, 4), (-6, -1), (-5, -8), (-8, -4), (1, 4), (2, -1), (1, -10), (9, 2), (-4, -3), (-2, -4)\}$

13) _____

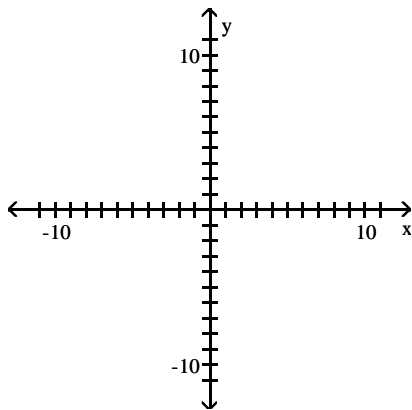

A)

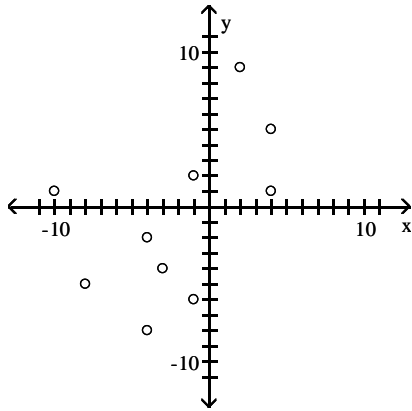

B)

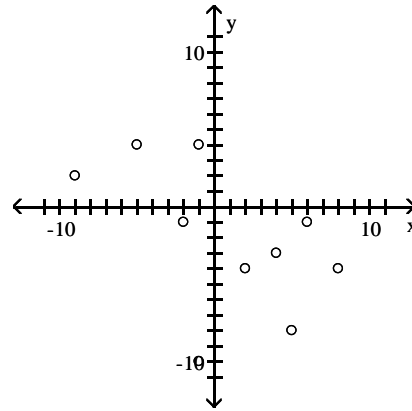

C)

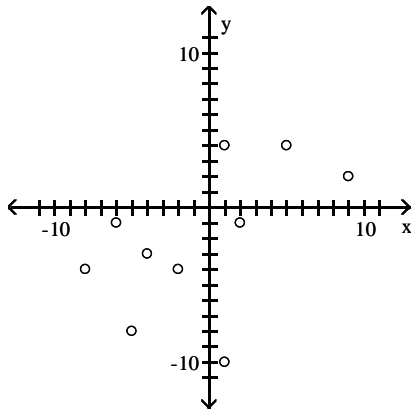

D)

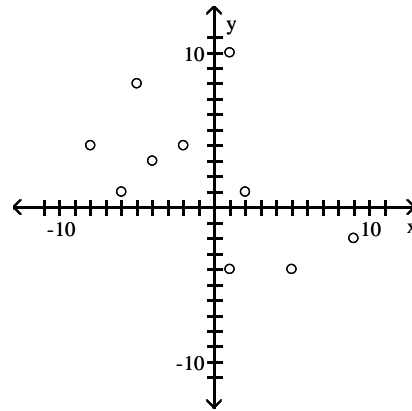

Evaluate the function as indicated.

14) Find $f(1)$ when $f(x) = x^2 + 2x + 3$.

A) -4

B) 0

C) 6

D) 2

14) _____

15) Find $f(7)$ when $f(x) = \sqrt{4x + 2}$.

A) $\sqrt{30}$

B) $\sqrt{15}$

C) $\sqrt{9}$

D) $\sqrt{6}$

15) _____

Specify the domain of the function.

16) $f(x) = \sqrt{8 - x}$

A) $x > \sqrt{8}$

C) $x \leq 8$

B) $x \neq 8$

D) All real numbers

16) _____

17) $f(x) = \frac{x}{x - 7}$

A) $x \neq 7$

C) All real numbers

B) $x \neq -7$

D) $x > 0$

17) _____

Determine if the relation is a function.

18)

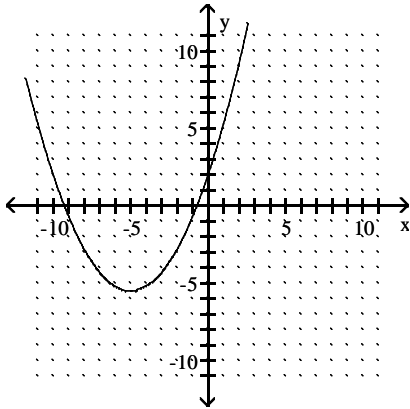

A) Not a function

B) Function

18) _____

19)

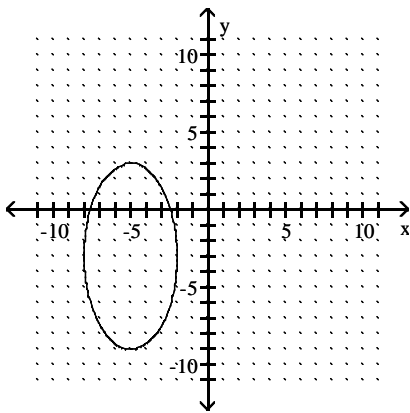

A) Function

B) Not a function

19) _____

Find the slope of the line that goes through the pair of points.

20) (5, -4) and (8, 7)

A) Undefined

B) $3\frac{3}{2}$

C) $3\frac{2}{3}$

D) 3

20) _____

State the slope of the graph of f.

21) $f(x) = \frac{8}{9}x - 3$

A) $\frac{8}{9}$

B) -3

C) Undefined

D) $\frac{9}{8}$

21) _____

Determine if the data in the table is linear or nonlinear.

22)

x	-3	2	4	5	7
y	-25	0	10	15	25

A) Linear

B) Nonlinear

22) _____

State whether the given function is linear and constant, linear but not constant, or nonlinear.

- 23) $f(x) = -9x^3 - 3x + 13$ 23) _____
 A) Nonlinear B) Linear, but not constant
 C) Linear, constant D) None of the above

Solve the problem.

- 24) Compute the average rate of change of $f(x) = 2x^2 + 3$ from $x_1 = 5$ to $x_2 = 8$. Round your answer to two decimal places. 24) _____
 A) 26.00 B) 26.91 C) 27.34 D) 23.29

- 25) The table gives the outside temperature in degrees Fahrenheit on a winter day in Death Valley, California. 25) _____

Time (A.M.)	7:00	8:00	9:00	10:00	11:00
Temp.	70	71	77	83	87

Calculate the average rate of change in temperature between 8:00 am and 11:00 am. Round your answer to two decimal places.

- A) 5.64° B) 6.36° C) 4.26° D) 5.33°

Identify the slope, y-intercept, and x-intercept.

- 26) 26) _____

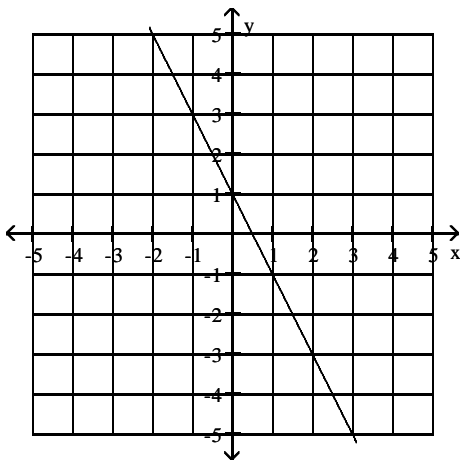

- A) Slope: 3; y-intercept: -1; x-intercept: $-\frac{1}{2}$
 B) Slope: -3; y-intercept: -1; x-intercept: $-\frac{1}{2}$
 C) Slope: -2; y-intercept: 1; x-intercept: $\frac{1}{2}$
 D) Slope: 2; y-intercept: 1; x-intercept: $\frac{1}{2}$

Write the equation of the line whose graph is shown.

27)

27) _____

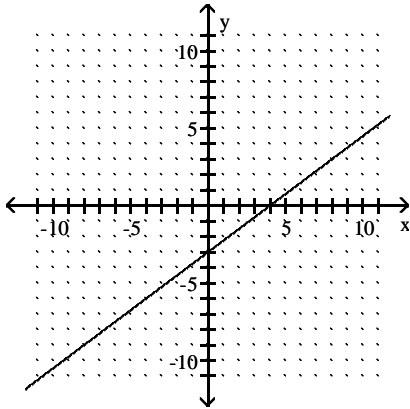

A) $y = -4x - 3$

B) $y = 4x - 3$

C) $y = \frac{4}{3}x + 4$

D) $y = \frac{3}{4}x - 3$

Write a formula for a linear function f whose graph satisfies the conditions.

28) Slope: $\frac{7}{3}$; y -intercept: -2

28) _____

A) $f(x) = -\frac{7}{3}x - 2$

B) $f(x) = \frac{7}{3}x + 2$

C) $f(x) = -\frac{7}{3}x + 2$

D) $f(x) = \frac{7}{3}x - 2$

Use the graph of f to determine the intervals where f is increasing and where f is decreasing.

29)

29) _____

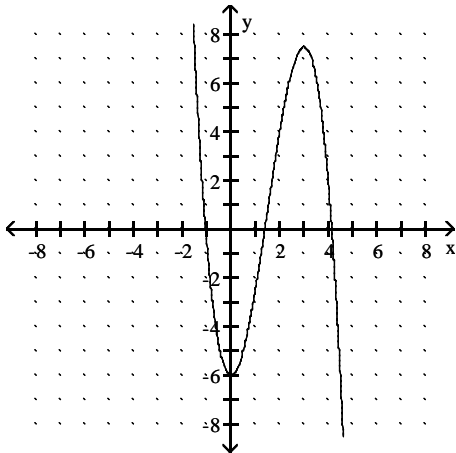

A) increasing: $[0, \infty)$; decreasing: $(-\infty, 0]$

B) increasing: $(-\infty, 1] \cup [2, \infty)$; decreasing: $[1, 2]$

C) increasing: $[0, 3]$; decreasing: $(-\infty, 0] \cup [3, \infty)$

D) increasing: $[2, \infty)$; decreasing: $(-\infty, 2]$

Identify where f is increasing or where f is decreasing, as indicated. Round your answer to two decimal places when appropriate.

30) $f(x) = -6x^2 + 24x$; increasing

30) _____

A) $[-2, \infty)$

B) $(-\infty, -2]$

C) $(-\infty, 2]$

D) $[2, \infty)$

Solve the problem.

39) In a chemistry class, 6 liters of a 4% silver iodide solution must be mixed with a 10% solution to get a 6% solution. How many liters of the 10% solution are needed? 39) _____

- A) 3 liters B) 2 liters C) 6 liters D) 4 liters

40) A rectangular Persian carpet has a perimeter of 244 inches. The length of the carpet is 26 in. more than the width. What are the dimensions of the carpet? 40) _____

- A) Width: 96 in.; length: 122 in. B) Width: 74 in.; length: 100 in.
C) Width: 48 in.; length: 74 in. D) Width: 109 in.; length: 135 in.

Write the following in interval notation.

41) $\{x \mid x > 5\}$ 41) _____

- A) $(5, -\infty)$ B) $(5, \infty)$ C) $(\infty, 5)$ D) $(-\infty, 5)$

Express the following in interval notation.

42)  42) _____

- A) $[-1, 3)$ B) $[-3, 1)$ C) $(-1, 3]$ D) $(-3, 1]$

Solve the inequality symbolically. Express the solution set in interval notation.

43) $36x + 24 > 6(5x + 9)$ 43) _____

- A) $(-\infty, 36)$ B) $(-\infty, 5)$ C) $(36, \infty)$ D) $(5, \infty)$

44) $5 < 8x - 5 \leq 9$ 44) _____

- A) $(\frac{5}{4}, \frac{7}{4}]$ B) $[\frac{5}{4}, \frac{7}{4})$ C) $(\frac{7}{4}, \frac{5}{4}]$ D) $[\frac{7}{4}, \frac{5}{4})$

Evaluate the function f at the indicated value.

45) 45) _____

$$f(7) \text{ for } f(x) = \begin{cases} 5x + 6, & \text{if } x \leq 0 \\ 4 - 6x, & \text{if } 0 < x < 6 \\ x, & \text{if } x \geq 6 \end{cases}$$

- A) 6 B) 41 C) -38 D) 7

Sketch a graph of the function.

46)

$$f(x) = \begin{cases} 4, & \text{if } x \geq 1 \\ -3 - x, & \text{if } x < 1 \end{cases}$$

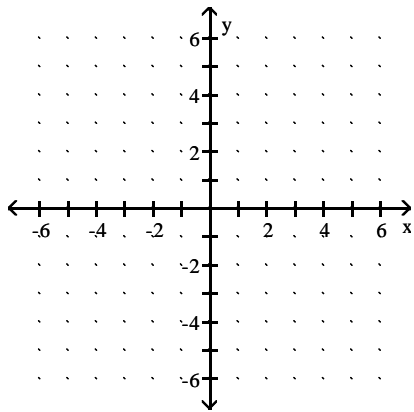

A)

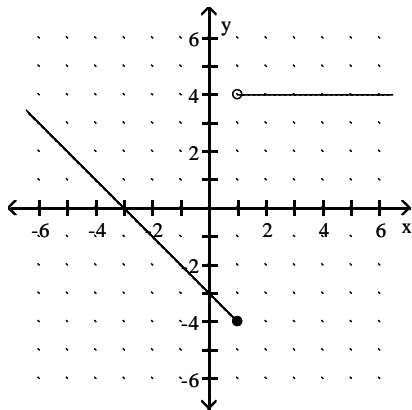

B)

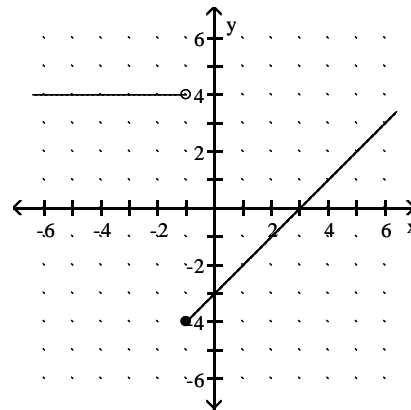

C)

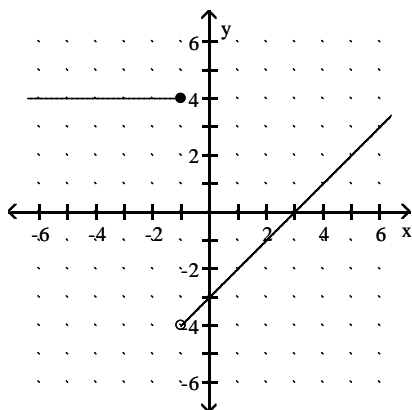

D)

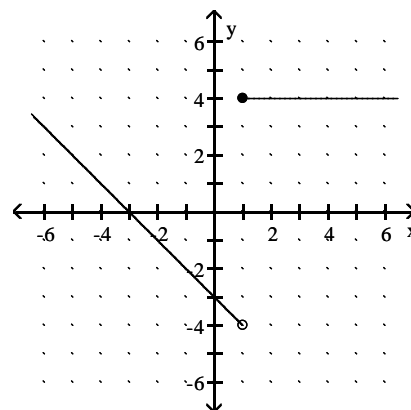

Solve the equation graphically, numerically, or symbolically. If appropriate, round the solution to hundredths.

47) $|3m + 2| + 6 = 12$

A) 2, -4

B) -1.33, 2.67

C) 1.33, -2.67

D) No solution

47) _____

Solve the inequality graphically, numerically, or symbolically, and express the solution in interval notation. Where appropriate, round to the nearest tenth.

48) $|r - 2.5| < 6$

48) _____

A) $(-\infty, -3.5) \cup (8.5, \infty)$

B) $(-\infty, -8.5) \cup (3.5, \infty)$

C) $(-3.5, 8.5)$

D) $(-8.5, 3.5)$

49) $|4.6x + 9.1| > 8$

49) _____

A) $(-\infty, -0.2) \cup (-3.7, \infty)$

B) $(-\infty, -3.7) \cup (-0.2, \infty)$

C) $(-0.2, -3.7)$

D) $(-3.7, -0.2)$

Use the graph of the quadratic function to determine the sign of the leading coefficient, the vertex, and the equation of the axis of symmetry.

50)

50) _____

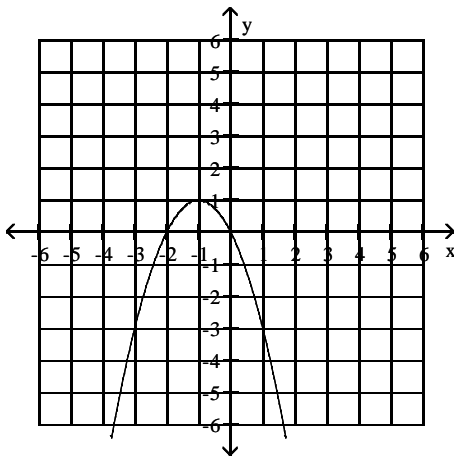

A) Positive; $(-1, 1)$; $x = -1$

B) Positive; $(1, 1)$; $x = 1$

C) Negative; $(-1, 1)$; $y = 1$

D) Negative; $(-1, 1)$; $x = -1$

Determine the vertex of the graph of f .

51) $f(x) = (x + 1)^2 - 3$

51) _____

A) $(-1, -3)$

B) $(-3, -1)$

C) $(3, 1)$

D) $(1, -3)$

52) $f(x) = \frac{1}{4}(x + 3)^2 + 4$

52) _____

A) $(4, -3)$

B) $(-3, 4)$

C) $(-4, 3)$

D) $(3, 4)$

Use the given graph of the quadratic function f to write its formula as $f(x) = a(x - h)^2 + k$.

53)

53) _____

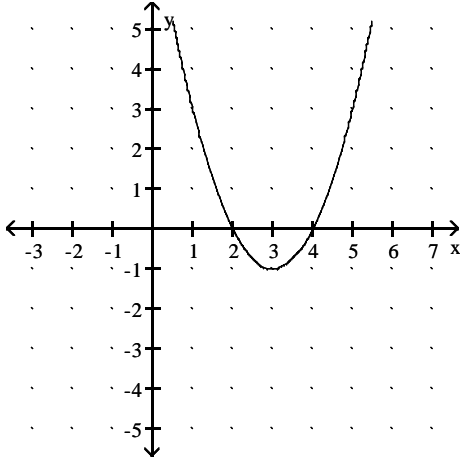

A) $f(x) = (x + 3)^2 - 1$

B) $f(x) = -(x - 3)^2 - 1$

C) $f(x) = (x - 3)^2 + 1$

D) $f(x) = (x - 3)^2 - 1$

Solve the quadratic equation.

54) $x^2 - 2x - 8 = 0$

54) _____

A) -8, 4

B) 8, -4

C) -4, 2

D) 4, -2

55) $3x^2 = 39$

55) _____

A) ± 13

B) 14

C) $\pm\sqrt{13}$

D) No real solutions

56) $3x^2 + 8x + 1 = 0$

56) _____

A) $\frac{-4 \pm \sqrt{19}}{3}$

B) $\frac{-4 \pm \sqrt{13}}{3}$

C) $\frac{-8 \pm \sqrt{13}}{3}$

D) $\frac{-4 \pm \sqrt{13}}{6}$

Solve the problem.

57) Your company uses the quadratic model $y = -4.5x^2 + 150x$ to represent the average number of new customers who will be signed on (x) weeks after the release of your new service. How many new customers can you expect to gain in week 12?

57) _____

A) 1746 customers

B) 576 customers

C) 252 customers

D) 1152 customers

Use the given graph of $f(x) = ax^2 + bx + c$ to solve the specified inequality.

58) $f(x) < 0$

58) _____

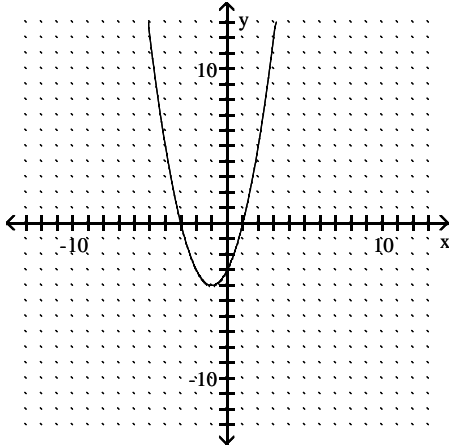

A) $-3 < x < 1$

B) $x < -3$

C) $x < -3$ or $x > 1$

D) No solutions

Solve the inequality.

59) $x^2 + 4x - 12 > 0$

59) _____

A) $x < -6$ or $x > 2$

B) $x < -6$

C) $x > 2$

D) $-6 < x < 2$

60) $x^2 - 3x - 10 \leq 0$

60) _____

A) $x \leq -2$

B) $x \leq -2$ or $x \geq 5$

C) $x \geq 5$

D) $-2 \leq x \leq 5$

Use the accompanying graph of $y = f(x)$ to sketch the graph of the indicated equation.

61) $y = f(x - 6)$

61) _____

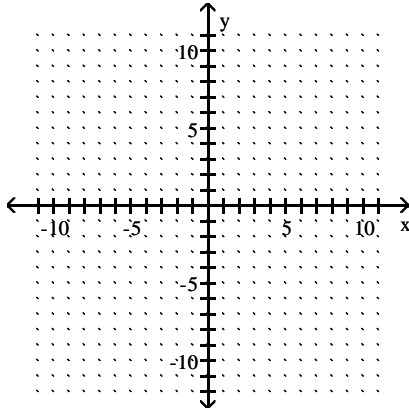
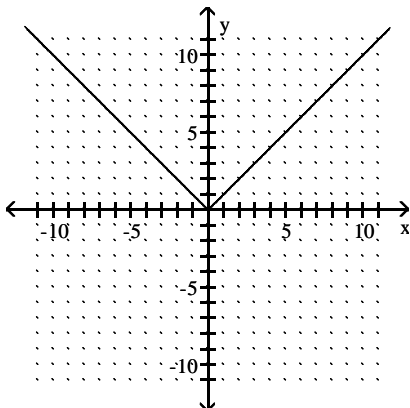

A)

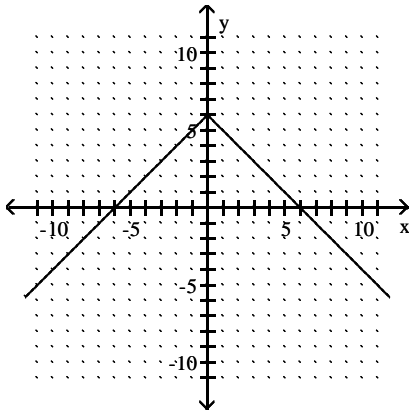

B)

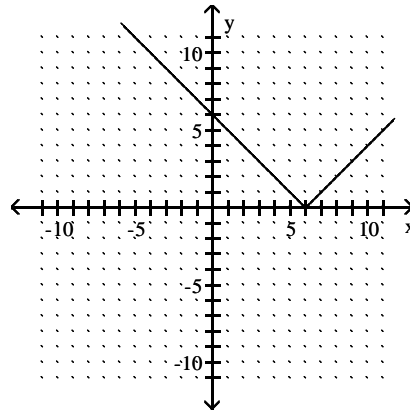

C)

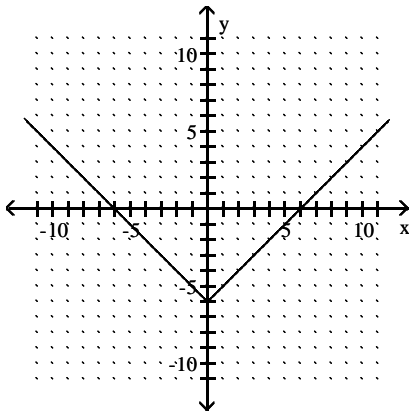

D)

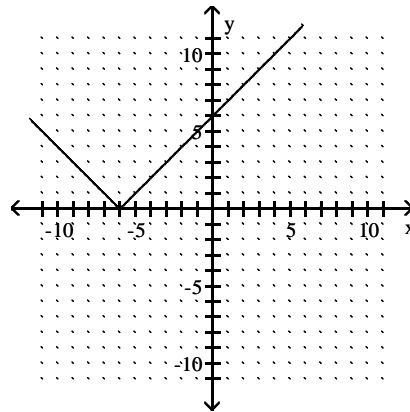

Find an equation that shifts the graph of f by the indicated amounts.

62) $f(x) = x^2 + 2x - 7$; right 5 units, down 13 units

A) $y = (x + 5)^2 + 2(x - 5) + 19$

C) $y = (x + 5)^2 + 2(x + 5) - 23$

B) $y = (x - 5)^2 + 2(x + 5) - 20$

D) $y = (x - 5)^2 + 2(x - 5) - 20$

62) _____

Find the domain of f .

63) $f(x) = \frac{x - 6}{x^2 - 4}$

A) $\{x \mid x \neq -2\}$

B) $\{x \mid x \neq 2\}$

C) $\{x \mid x \neq \pm 2\}$

D) $\{x \mid x \neq 6\}$

63) _____

Solve the problem.

- 64) A rock is thrown vertically upward from the surface of the moon at a velocity of 28 m/sec. The graph shows the height y of the rock, in meters, after x seconds. Estimate and interpret the turning point.

64) _____

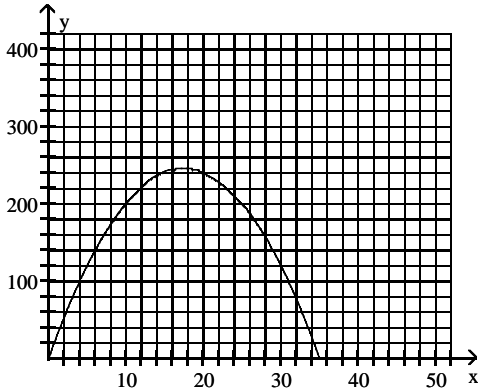

- A) The turning point is at approximately (17.5, 245). This is the point at which the rock reaches its maximum velocity and starts to slow down.
- B) The turning point is at approximately (35, 0). This is the point at which the rock reaches the surface of the moon again.
- C) The turning point is at approximately (17.5, 245). This is the point at which the rock reaches its maximum height and starts to fall back towards the surface of the moon.
- D) The turning point is at approximately (35, 245). This is the point at which the rock reaches its maximum height and starts to fall back towards the surface of the moon.

Identify any vertical asymptotes in the graph.

65)

65) _____

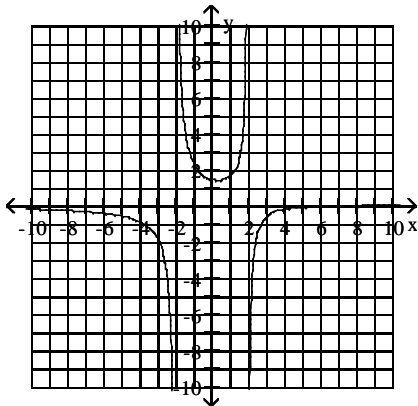

- A) $x = -2$
- B) $x = 2$
- C) $x = 2, x = -2$
- D) $x = 6$

Use the given functions to find the requested function.

- 66) $f(x) = 6x + 8$, $g(x) = 4x^2$
Find $(fg)(x)$.

66) _____

- A) $24x + 32$
- B) $24x^2 + 32x$
- C) $24x^3 + 32x^2$
- D) $4x^2 + 6x + 8$

Identify any horizontal asymptotes in the graph.

67)

67) _____

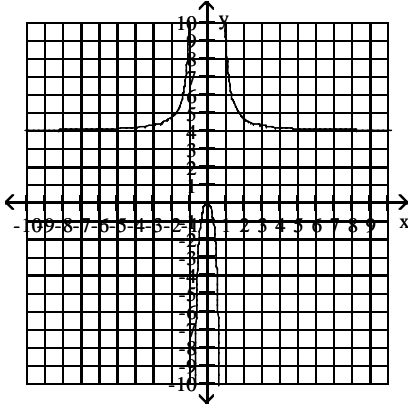

A) $y = 3$

B) $y = \sqrt{3}$

C) $y = 4$

D) None

Evaluate as instructed.

68) Evaluate $(f+g)(3)$.

68) _____

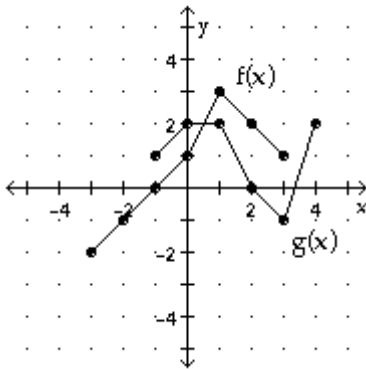

A) 1

B) -1

C) 0

D) 3

Solve the problem.

69) Find $(f \circ g)(2)$ when $f(x) = 4x + 6$ and $g(x) = 1/x$.

69) _____

A) $\frac{11}{2}$

B) $\frac{1}{14}$

C) 8

D) $\frac{29}{2}$

Complete numerical representations for the functions f and g are given. Evaluate the expression, if possible.

70) $(f \circ g)(4)$

70) _____

x	1	6	8	12
$f(x)$	-2	8	0	12

x	-5	-2	1	4
$g(x)$	1	-7	6	8

A) Undefined

B) 8

C) 0

D) 6

Use the graph to determine whether the function is one-to-one.

71)

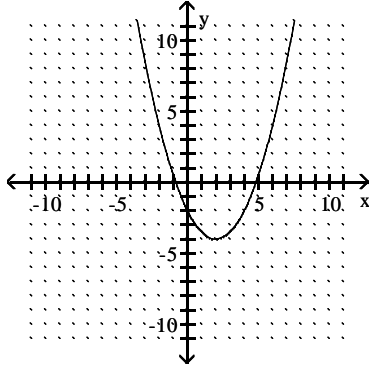

A) Yes

B) No

71) _____

Determine whether or not the function is one-to-one.

72) $f(x) = 7x^3 - 4$

A) Yes

B) No

72) _____

Find a symbolic representation for $f^{-1}(x)$.

73) $f(x) = x^3 - 1$

A) Not a one-to-one function

B) $f^{-1}(x) = \sqrt[3]{x - 1}$

C) $f^{-1}(x) = \sqrt[3]{x + 1}$

D) $f^{-1}(x) = \sqrt{x + 1}$

73) _____

Find either a linear or an exponential function that models the data in the table.

74)

x	0	1	2	3	4
y	7	28	112	448	1792

A) $f(x) = \frac{1}{21}x + 7$

B) $f(x) = 7(4)^x$

C) $f(x) = 4(7)^x$

D) $f(x) = 21x + 7$

74) _____

Graph the exponential function.

75) $y = 3^x$

75) _____

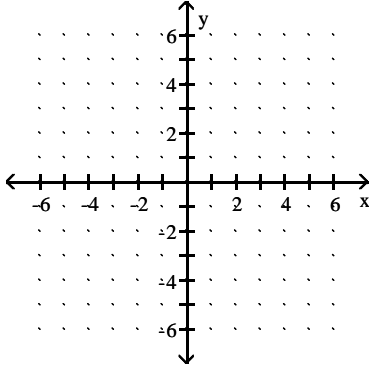

A)

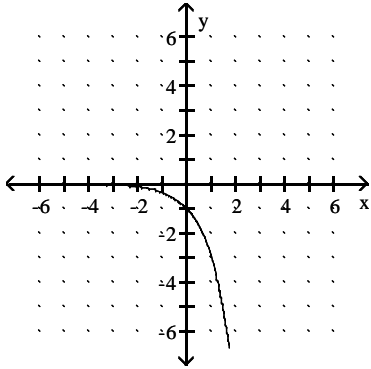

B)

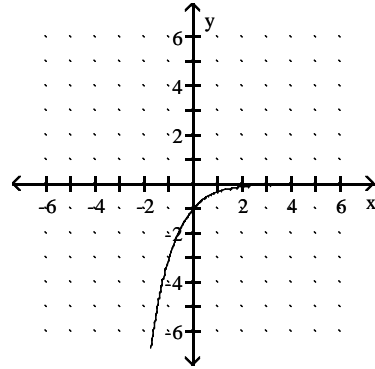

C)

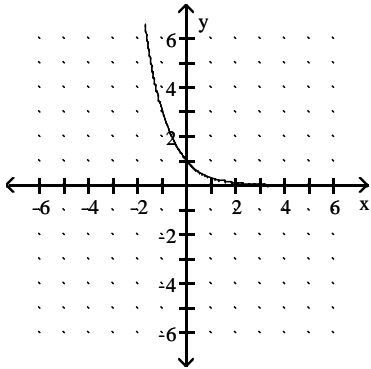

D)

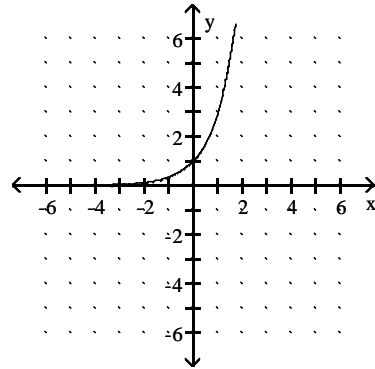

Determine a formula for the exponential function.

76)

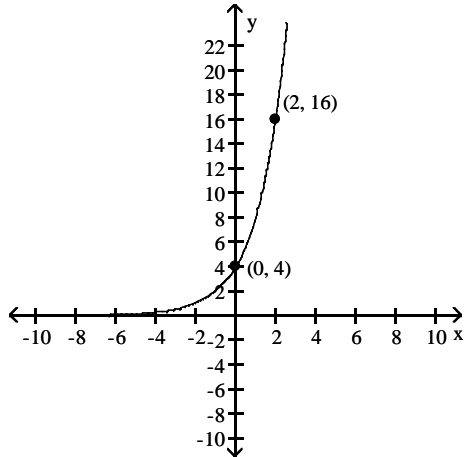

76) _____

A) $f(x) = 16 \cdot 2^x$

B) $f(x) = 4 \cdot 0.5^x$

C) $f(x) = 4 \cdot 16^x$

D) $f(x) = 4 \cdot 2^x$

Use the compound interest formula to determine the final value of the given amount.

77) \$12,000 at 11% compounded quarterly for 6 years

77) _____

A) \$22,395.63

B) \$11,011.51

C) \$23,011.51

D) \$22,444.97

78) \$1000 at 5% compounded continuously for 19 years

78) _____

A) \$2585.71

B) \$1301.03

C) \$2,742,613.74

D) \$44,701.18

Evaluate the expression by hand, if possible.

79) $\log 10,000 + \log 0.001$

79) _____

A) 1

B) -1

C) -7

D) 7

Evaluate the logarithm.

80) $\log_8 \left(\frac{1}{64} \right)$

80) _____

A) -2

B) 8

C) 2

D) -8

Expand the expression.

81) $\log_3 \frac{x^3 y^5}{6}$

81) _____

A) $3 \log_3 x - 5 \log_3 y - \log_3 6$

B) $3 \log_3 x + 5 \log_3 y - \log_3 6$

C) $(3 \log_3 x)(5 \log_3 y) - \log_3 6$

D) $3 \log_3 x + 5 \log_3 y + \log_3 6$

Write the expression as one logarithm.

82) $\log_b x + \log_b y$

82) _____

A) $\log_{2b} xy$

B) $\log_b xy$

C) $\log_b (x + y)$

D) $\log_{2b} (x + y)$

Use the change of base formula to approximate the logarithm to four decimal places.

83) $\log_8 37.94$

83) _____

A) 1.7485

B) 0.5719

C) 1.5791

D) 4.7425

Solve the problem.

84) Wind speed varies in the first twenty meters above the ground. For a particular day, let $f(x) = 9.2 \ln x + 2.1$ compute the wind speed x meters above the ground. At what height is the wind speed 5 meters per second? Round results to the nearest hundredth.

84) _____

A) 1.37

B) 0.73

C) 0.32

D) 0.24

Solve the exponential equation.

85) $(3.3)^x = 43$

85) _____

A) 3.1503

B) 3.2737

C) 3.138

D) 3.1626

Solve the logarithmic equation.

86) $\log(x + 9) = 1 - \log x$

86) _____

A) -1

B) 1

C) -1, 10

D) -10, 1

Solve the problem.

87) Suppose A_0 dollars is deposited in a savings account paying 5.0% interest compounded continuously. After x years the account will contain $A(x) = A_0 e^{0.05x}$ dollars. If \$280 is initially deposited in this account, how much would be in the account after 10 years? Round to the nearest cent.

87) _____

A) \$82.22

B) \$461.64

C) \$1.65

D) \$294.36

88) One method to determine the time since an animal died is to estimate the percentage of carbon-14 remaining in its bones. The percent P in decimal form of carbon-14 remaining x years is given by $P(x) = e^{-0.000121x}$. Approximate (to the nearest whole year) the age of a fossil if there is 5% of carbon-14 remaining.

88) _____

A) 5728

B) 10,752

C) 24,758

D) -13,301

A system of two linear equations has been solved graphically. Use the graph to find any solutions.

89)

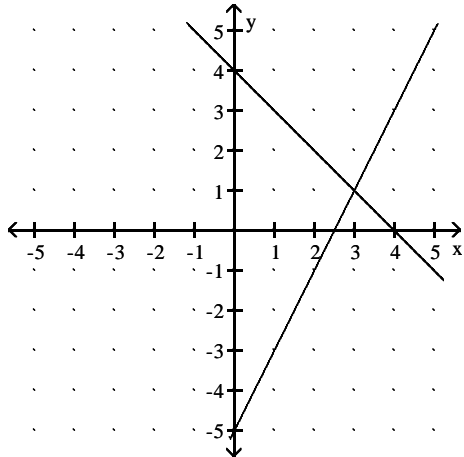

89) _____

A) (3, 1)

B) No solutions

C) (1, 3)

D) Infinite number of solutions

Solve the system of linear equations.

90) $x - 2y = 7$
 $6x - 2y = 52$

90) _____

A) (-9, 0)

B) (9, 1)

C) (10, 0)

D) No solution

Solve the problem.

91) There were 44,000 people at a ball game in Los Angeles. The day's receipts were \$310,000. How many people paid \$11 for reserved seats and how many paid \$5 for general admission?

91) _____

A) 21,500 paid \$11 and 22,500 paid \$5

B) 15,000 paid \$11 and 29,000 paid \$5

C) 29,000 paid \$11 and 15,000 paid \$5

D) 22,500 paid \$11 and 21,500 paid \$5

Graph the solution set to the inequality.

92) $x + 3y \geq -3$

92) _____

A)

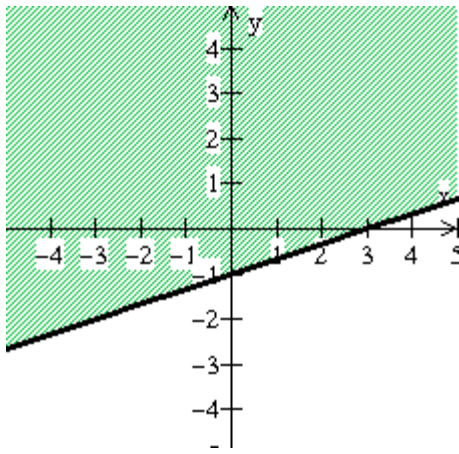

B)

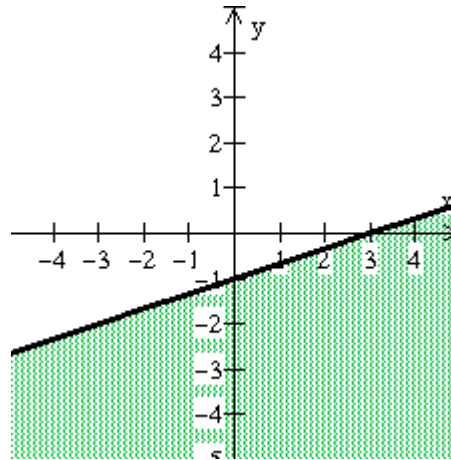

C)

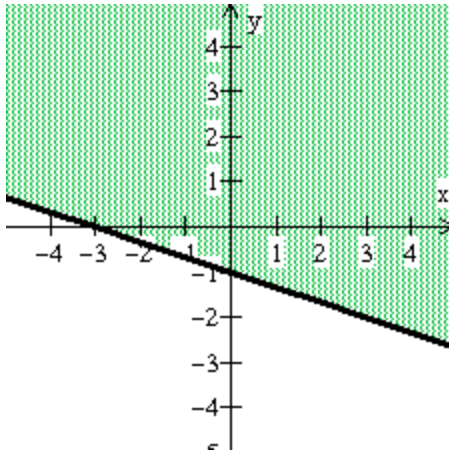

D)

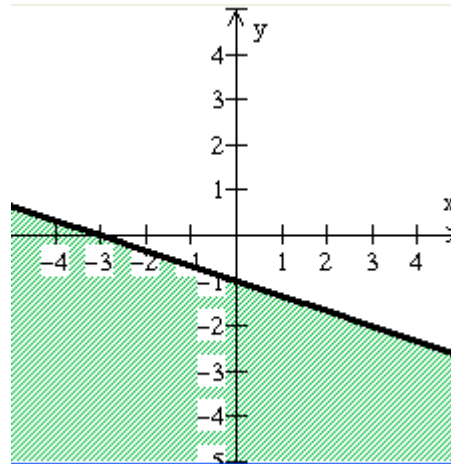

Match the system of inequalities with the appropriate graph.

93) $x + 2y \leq 2$
 $x + y \geq 0$

93) _____

A)

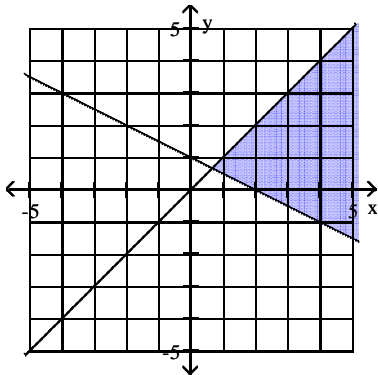

B)

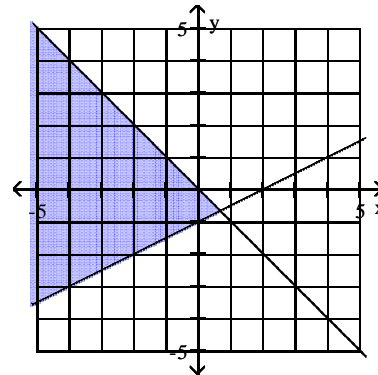

C)

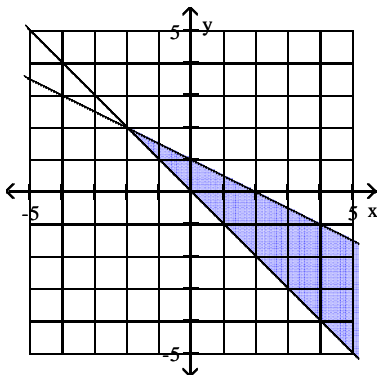

D)

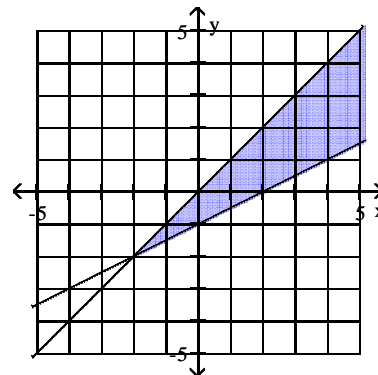

Use a graphing calculator to solve the system of equations. Round your solutions to one decimal place.

94) $2.9x + 1.6y - 2.0z = 4.1$
 $5.6x - 6.7y + 1.9z = -2.1$
 $3.1x + 4.2y + 4.4z = 9.2$

94) _____

A) (1.0, 1.2, 0.3)

B) (0.5, 0.6, 0.1)

C) (3.8, 4.8, 1.1)

D) (1.9, 2.4, 0.6)

Perform the matrix operation.

95) Let $A = \begin{bmatrix} 1 & 3 \\ 2 & 6 \end{bmatrix}$ and $B = \begin{bmatrix} 0 & 4 \\ -1 & 6 \end{bmatrix}$. Find $2A + B$.

95) _____

A) $\begin{bmatrix} 2 & 14 \\ 2 & 24 \end{bmatrix}$

B) $\begin{bmatrix} 2 & 7 \\ 3 & 12 \end{bmatrix}$

C) $\begin{bmatrix} 2 & 10 \\ 1 & 12 \end{bmatrix}$

D) $\begin{bmatrix} 2 & 10 \\ 3 & 18 \end{bmatrix}$

Perform the indicated calculation.

96) Calculate $a_{21} + a_{22}a_{12}$ for the matrix $A = \begin{bmatrix} -4 & 5 & -1 \\ 4 & -2 & 2 \end{bmatrix}$.

96) _____

A) -6

B) -4

C) 285

D) -3

If possible, find the matrix product of AB.

$$97) A = \begin{bmatrix} 1 & 3 & -3 \\ 2 & 0 & 5 \end{bmatrix}; B = \begin{bmatrix} 3 & 0 \\ -3 & 1 \\ 0 & 5 \end{bmatrix}$$

97) _____

A) Undefined

$$B) AB = \begin{bmatrix} -12 & -6 \\ 25 & -6 \end{bmatrix}$$

$$C) AB = \begin{bmatrix} -6 & -12 \\ 6 & 25 \end{bmatrix}$$

$$D) AB = \begin{bmatrix} 3 & 2 & 0 \\ 0 & 0 & 25 \end{bmatrix}$$

Find A^{-1} .

$$98) A = \begin{bmatrix} 4 & -6 \\ 2 & 4 \end{bmatrix}$$

98) _____

$$A) A^{-1} = \begin{bmatrix} \frac{1}{7} & \frac{3}{14} \\ -\frac{1}{14} & \frac{1}{7} \end{bmatrix}$$

$$B) A^{-1} = \begin{bmatrix} -\frac{1}{14} & \frac{1}{7} \\ \frac{1}{7} & \frac{3}{14} \end{bmatrix}$$

$$C) A^{-1} = \begin{bmatrix} \frac{1}{7} & -\frac{3}{14} \\ \frac{1}{14} & \frac{1}{7} \end{bmatrix}$$

Use technology to calculate $\det A$.

$$99) A = \begin{bmatrix} 0 & 3 & 4 & 1 \\ 0 & 4 & 3 & 9 \\ 5 & 9 & 1 & 4 \\ 6 & 7 & 3 & 2 \end{bmatrix}$$

99) _____

A) 15

B) -736

C) 5

D) 33

Solve the linear system for y by computing with a calculator. Round to the nearest tenth, as necessary.

$$100) \begin{aligned} 1.2x + 1.0y - 3.1z &= 2.7 \\ 3.6x - 6.8y + 1.3z &= -2.5 \\ 4.0x + 4.5y + 3.9z &= 11.0 \end{aligned}$$

100) _____

A) $y = 4.5$

B) $y = 1.1$

C) $y = 2.3$

D) $y = 0.6$

Answer the question.

101) In how many ways can you answer the questions on an exam that consists of 11 multiple choice questions, each of which has 3 answer choices?

101) _____

A) 1331

B) 177,987

C) 176,917

D) 177,147

102) How many automobile license plates can be made involving 3 letters followed by 3 digits, if letters cannot be repeated (used more than once) but digits can be repeated?

102) _____

A) 15,869,020

B) 15,571,400

C) 17,576,000

D) 15,600,000

Solve.

103) How many ways can a president, vice-president, and secretary be chosen from a club with 11 members?

103) _____

A) 6

B) 33

C) 990

D) 165

Solve the problem.

- 104) There are 13 people in a club. A committee of 4 persons is to be chosen to represent the club at a conference. In how many ways can the committee be chosen? 104) _____
- A) 1141 B) 715 C) 17,160 D) 4290

- 105) How many committees of 5 people can be selected from 9 men and 7 women if the committee must have 3 men and 2 women? 105) _____
- A) 1904 B) 1764 C) 21,168 D) 1744

Find the probability of the event.

- 106) A bag contains 5 red marbles, 4 blue marbles, and 1 green marble. What is the probability of choosing a marble that is not blue when one marble is drawn from the bag? 106) _____
- A) $\frac{5}{3}$ B) 6 C) $\frac{3}{5}$ D) $\frac{2}{5}$

Solve the problem.

- 107) The distribution of B.A. degrees conferred by a local college is listed below, by major. 107) _____

<u>Major</u>	<u>Frequency</u>
English	2,073
Mathematics	2,164
Chemistry	318
Physics	856
Liberal Arts	1,358
Business	1,676
Engineering	<u>868</u>
	9,313

What is the probability that a randomly selected degree is not in Mathematics?

- A) 0.303 B) 0.232 C) 0.768 D) 0.682

Answer Key

Testname: MATH 1710-COLLEGE ALGEBRA FINAL REVIEW

- | | | |
|-------|--------|--------|
| 1) C | 51) A | 101) D |
| 2) B | 52) B | 102) D |
| 3) D | 53) D | 103) C |
| 4) C | 54) D | 104) B |
| 5) B | 55) C | 105) B |
| 6) B | 56) B | 106) C |
| 7) B | 57) D | 107) C |
| 8) D | 58) A | |
| 9) B | 59) A | |
| 10) A | 60) D | |
| 11) A | 61) B | |
| 12) C | 62) D | |
| 13) C | 63) C | |
| 14) C | 64) C | |
| 15) A | 65) C | |
| 16) C | 66) C | |
| 17) A | 67) C | |
| 18) B | 68) C | |
| 19) B | 69) C | |
| 20) C | 70) C | |
| 21) A | 71) B | |
| 22) A | 72) A | |
| 23) A | 73) D | |
| 24) A | 74) B | |
| 25) D | 75) D | |
| 26) C | 76) D | |
| 27) D | 77) C | |
| 28) D | 78) A | |
| 29) C | 79) A | |
| 30) C | 80) A | |
| 31) D | 81) B | |
| 32) C | 82) B | |
| 33) C | 83) A | |
| 34) C | 84) A | |
| 35) D | 85) A | |
| 36) C | 86) B | |
| 37) B | 87) B | |
| 38) B | 88) C | |
| 39) A | 89) A | |
| 40) C | 90) B | |
| 41) B | 91) B | |
| 42) B | 92) C | |
| 43) D | 93) C | |
| 44) A | 94) A | |
| 45) D | 95) D | |
| 46) D | 96) A | |
| 47) C | 97) C | |
| 48) C | 98) A | |
| 49) B | 99) B | |
| 50) D | 100) B | |